

INSTALLATION

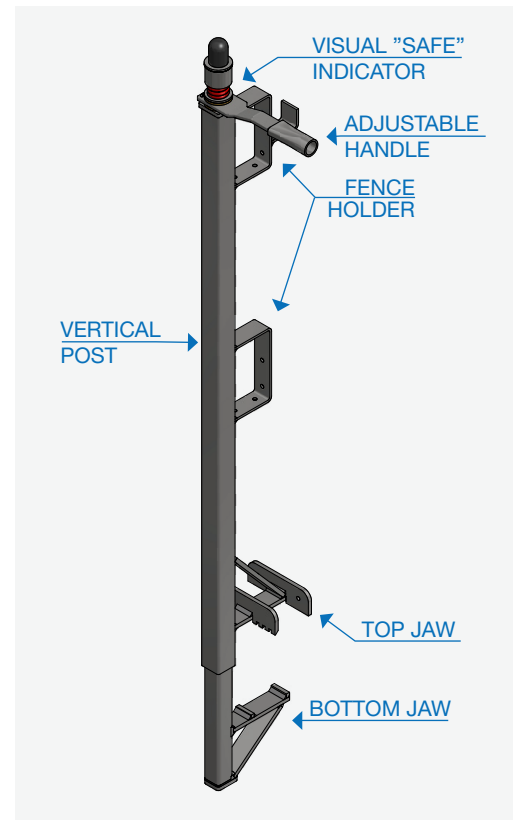
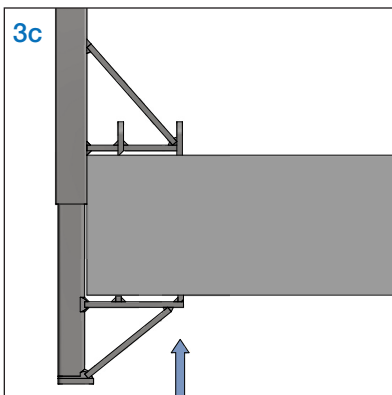
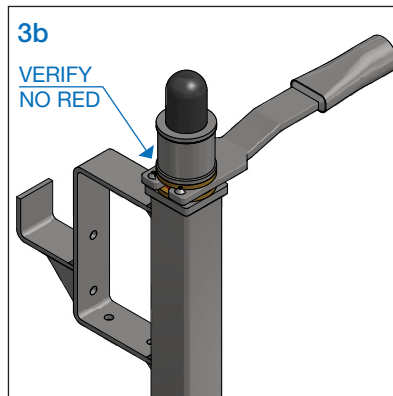
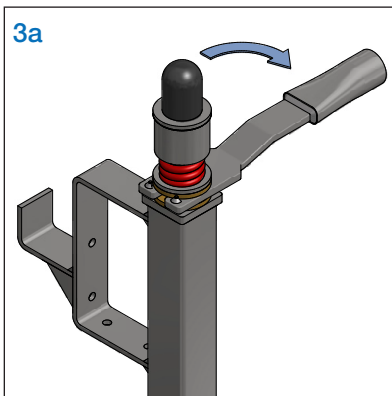
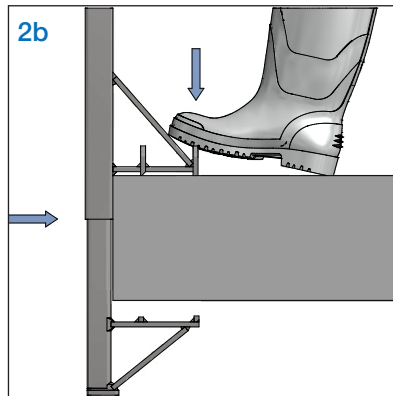
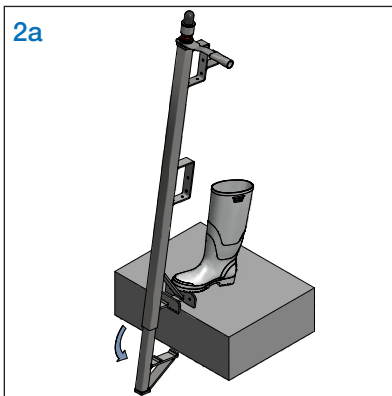
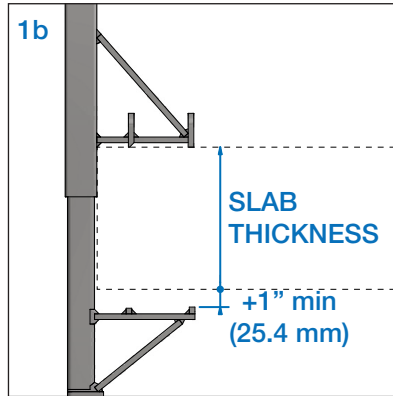
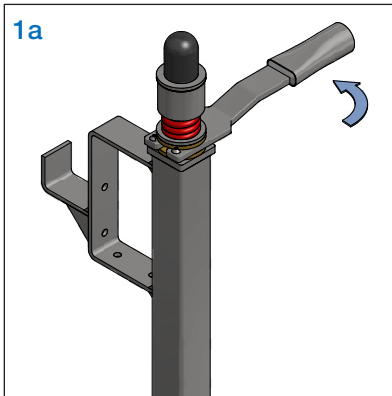

STEP 1

Turn the adjustment handle counterclockwise to open the jaw.

Set the jaw opening to slab thickness + 1" (24.5 mm).

STEP 2

Position the slab grab with the vertical post against the slab edge.

Step on the top jaw and rotate until vertical post is plumb and flush with the full face of the slab edge.

STEP 3

Tighten the jaw to the slab turning the handle clockwise until the visual indicator has no visible red.

RAILINGS

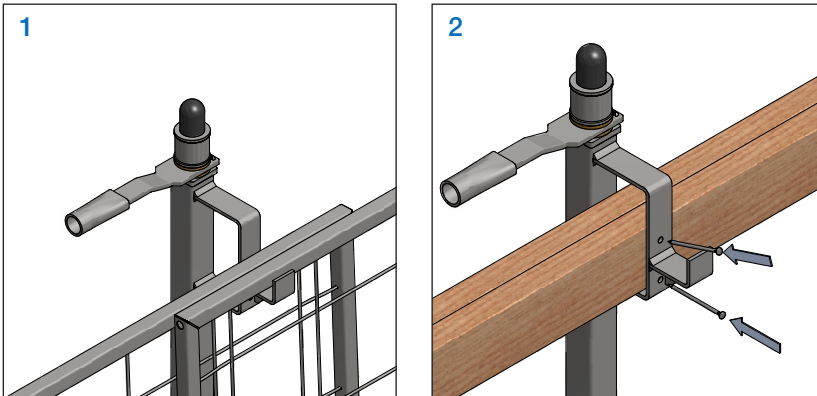

When all the steps are completed, the Slab Grab is ready for the Speed Fence or temporary guardrail to be installed
Maximum spacing of Slab Grab not to exceed 9' (2743 mm)

WEIGHT: 32 lbs / 14.5 kg

SLAB THICKNESS:

MIN 3" / 76 mm; MAX 26" / 660 mm

STEP 1

Connect the Speed Fence to the Guard Holder as per the Speed Fence installation instructions.

STEP 2

Slide 2 x 4 (38 mm x 89 mm) lumber through the Guard Holders and nail with (2) 3" long common nails.

ALWAYS REFER TO GENERAL SAFETY NOTES BEFORE INSTALLATION

SPEED  **EDGE**

FOR TECHNICAL ASSISTANCE:

info@speededge.ca

905-857-9888

speededge.ca