



**SPEED**  **EDGE**

**SPEED EDGE™**  
**PROTECTION PRODUCTS**

**FENCE  
& POST  
SYSTEM**

[www.speededge.ca](http://www.speededge.ca)



5



1

- 1 Speed Post
- 2 High Post
- 3 Shark Stand
- 4 Beam Clamp
- 5 Guardrail Bracket
- 6 Slab Grab
- 7 Safety Fence



2

7

4

6

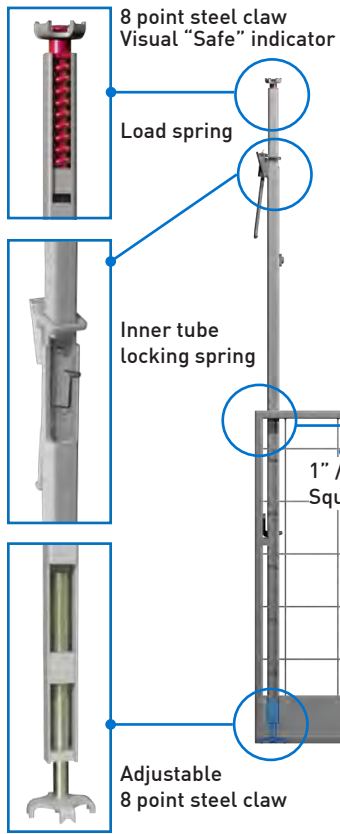

## SPEED FENCE 9 FT:

PRODUCT CODE: KF9642

WEIGHT: 45 lbs / 20.5 kg

MEASUREMENTS:

9'6" x 42" high / 2.9 m x 1.07 m high  
6" / 152.4 mm toeboard

FEATURES:

- > Constructed from 1" / 25.4 mm steel tubing
- > Built-in post locking latch

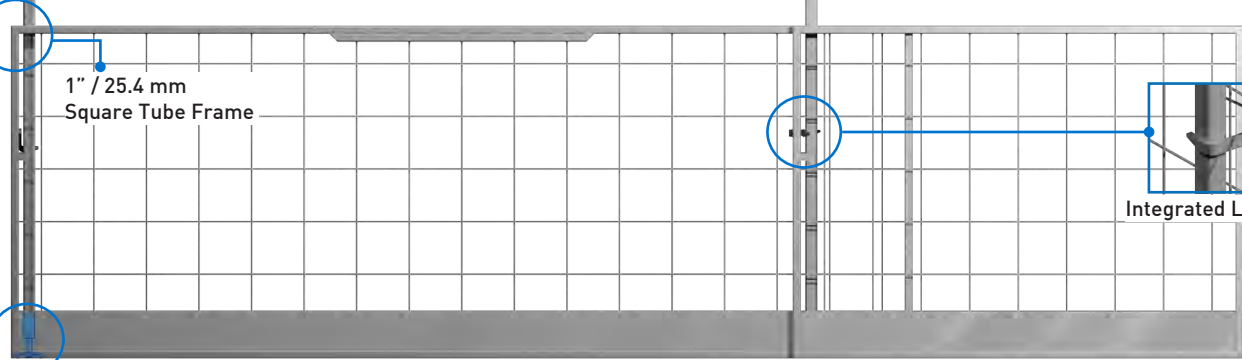

## SPEED FENCE 5 FT:

PRODUCT CODE: KF542

WEIGHT: 24.1 lbs / 11 kg

MEASUREMENTS:

4'9" x 42" high / 1.45 m x 1.07 m high  
6" / 152.4 mm toeboard

FEATURES:

- > Constructed from 1" / 25.4 mm steel tubing
- > Built-in post locking latch



**MEETS CURRENT HEALTH & SAFETY REGULATIONS  
LABOR-EFFICIENT INSTALLATION | GALVANIZED**

### PRIMARY POST:



#### SPEED POST

PRODUCT CODE: SP

WEIGHT: 24.5 lbs / 11.1 kg

MEASUREMENTS:

6'6" to 10'8" high /  
1.9 m to 3.25 m high

- > Visual "Safe" Indicator
- > Secure Lock
- > No tools required

### SPECIALTY POSTS:

#### HIGH POST

PRODUCT CODE: HP

WEIGHT: 28 lbs / 12.7 kg

MEASUREMENTS:

8'2" to 13'6" high /  
2.5 m to 4.1 m high

- > Visual "Safe" Indicator
- > No tools required



#### SHARK STAND

PRODUCT CODE: SS

WEIGHT: 15.2 lbs / 6.9 kg

MEASUREMENTS: 42" / 1.07 m

- > Fasten to plywood or concrete
- > Use with Speed Fence or
- > Use with 2x4 lumber railings

#### CURB GRAB

PRODUCT CODE: CG

WEIGHT: 27 lbs / 12.3 kg

MEASUREMENTS: 42" / 1.07 m

ADJUST UP TO 21" / 0.53 m curb

- > Visual "Safe" Indicator
- > Use with Speed Fence or
- > Use with 2x4 lumber railings
- > Collapses for portability



#### SLAB GRAB

PRODUCT CODE: SG

WEIGHT: 32 lbs / 14.5 kg

MEASUREMENTS: 42" / 1.07 m

SLAB THICKNESS UP TO 26" / 0.66 m

- > Visual "Safe" Indicator
- > Use with Speed Fence or
- > Use with 2x4 lumber railings



**FAST. SAFE. SIMPLE.**

## OTHER PRODUCTS BY SPEED-EDGE:

### GUARDRAIL BRACKET

PRODUCT CODE: GRBAL

WEIGHT: 16.4 lbs / 7.5 kg

- > Fasten to Aluma Beam Table Forms
- > Advanced alternative to Aluma Guardrail Beam and Post Socket
- > Allows for guardrail post height up to 70" / 1.7 m
- > Load tested to allow for solid sheeting of guardrail



### PARAPET POST

PRODUCT CODE: PP

WEIGHT: 19.7 lbs / 9 kg

MEASUREMENTS: 42" / 1.07 m

MAX SPACING: 9' / 2743 mm

- > Use with Speed Fence or
- > Use with 2x4 lumber railings
- > Fasten to concrete parapet, wall or curb



### BEAM CLAMP

PRODUCT CODE: BC

WEIGHT: 27.3 lbs / 13.4 kg

MEASUREMENTS: 42" / 1.07 m

MAX SPACING: 9' / 2743 mm

- > Use with Speed Fence or
- > Use with 2x4 lumber railings



## DEBRIS NETTING:



### SPEED FAN

PRODUCT CODE: SF

WEIGHT: 242 lbs / 110 kg

LENGTH: 13.1 ft / 4 m or 19.7 ft / 6m

WIDTH: 9.8 ft / 3 m projection from slab

2 layer net with optional fine debris mesh

- > Offers protection to pedestrians, workers, and private property from falling objects and debris during construction
- > Completely independent of the tower crane. Climb and position Speed Fan with Mobile Lifting Device
- > Installs to concrete floor edge and parapets
- > Easy to close net for operations
- > Follow formwork every 3 floors

ALWAYS READ THE INSTALLATION INSTRUCTIONS BEFORE ASSEMBLING

# SPEED EDGE

**TORONTO**  
4 Wheeler Drive  
Bolton, ON L7E 4H8  
T: 905-857-9888  
F: 905-951-1180

**CALGARY**  
10-6304 Burbank Rd. SE  
Calgary, AB T2H 2C2  
T/F: 403-723-0801

**VANCOUVER**  
5161 Byrne Rd.  
Burnaby, BC V5J 3H6  
T/F: 403-723-0801

DISTRIBUTED BY:

info@speededge.ca  
www.speededge.ca