

CURB GRAB

CG

Curb-Mounted Guardrail Post

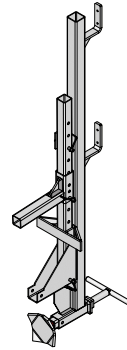
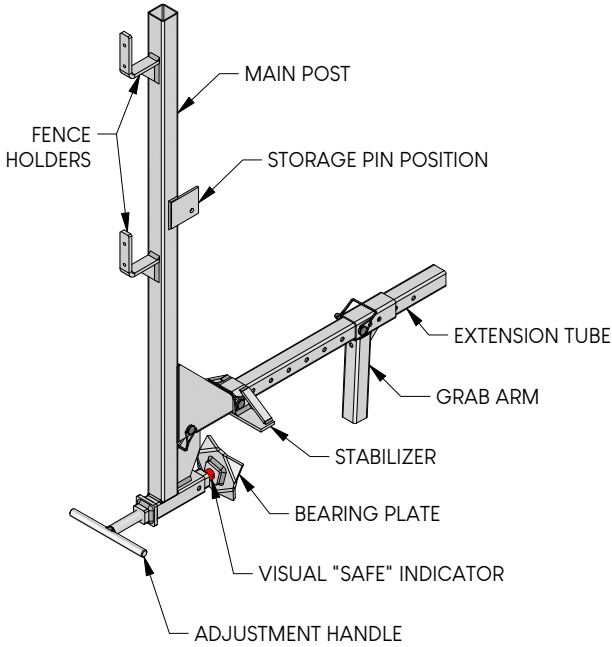

UNIT FOLDS FOR COMPACT STORAGE AND TRANSPORTATION

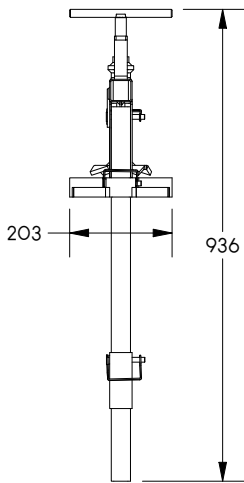
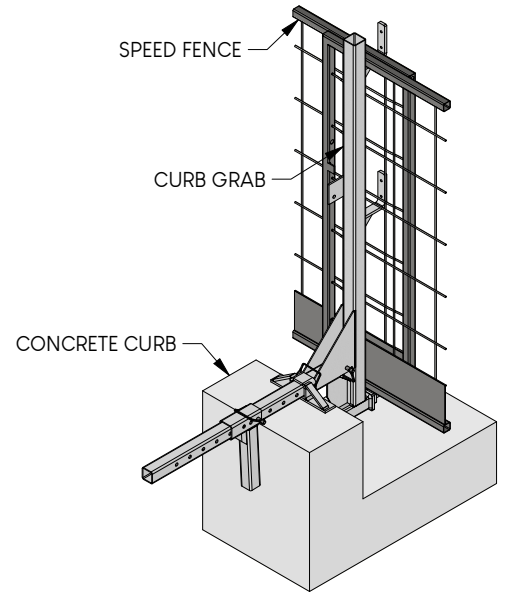

TOP VIEW

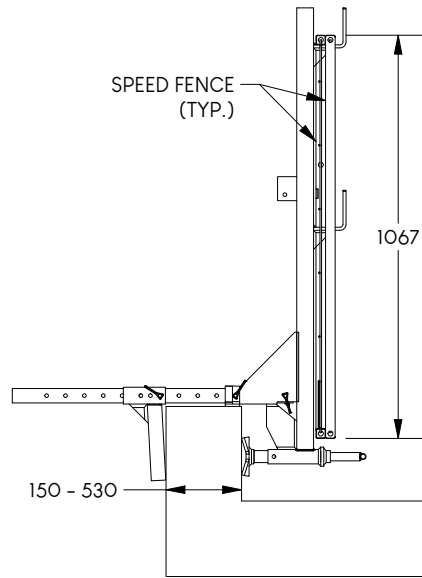

SPEED FENCE APPLICATION

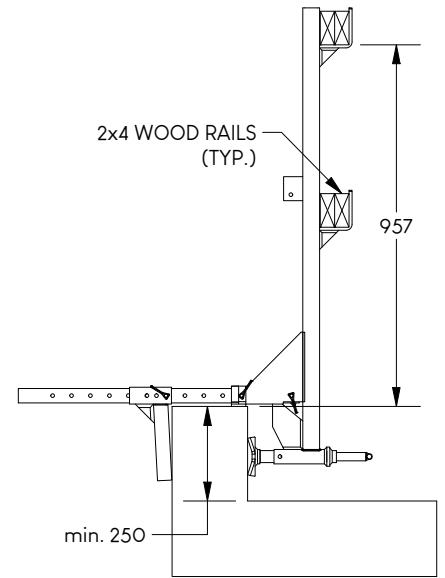

WOOD RAIL APPLICATION

Compliant with load requirements of all Canadian Provincial Regulations for Construction Projects.

*Maximum post spacing applies when the guardrail system consists of only Speed Edge products.

Please inquire regarding compliance in other jurisdictions or for special case scenarios.

Refer to manual for complete installation instructions.

ALL MEASUREMENTS IN mm, U.N.O.

Weight	12.2 kg
*Max. Spacing	2743 mm