

FACE BRACKET

FB

Universal Face-Mounting Bracket

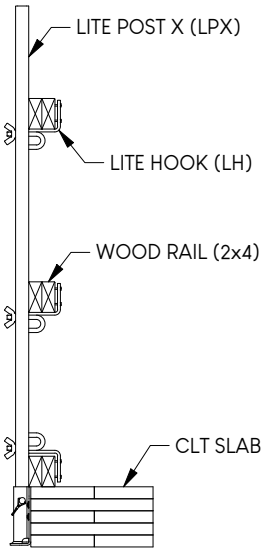
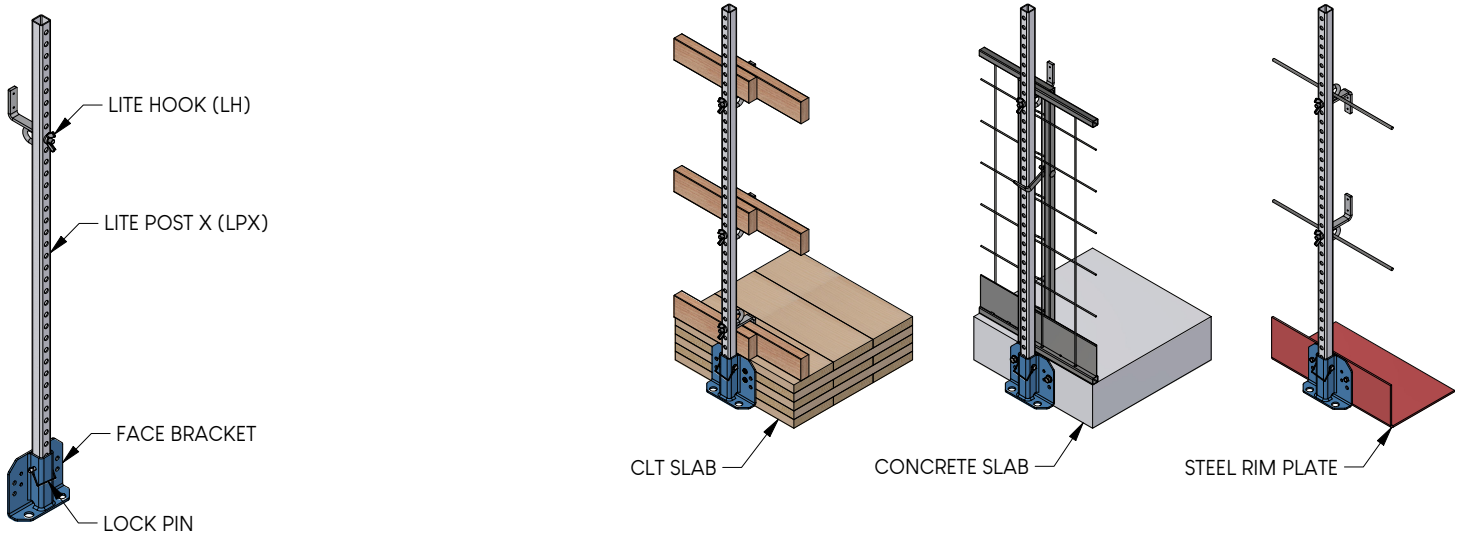

WOOD APPLICATION

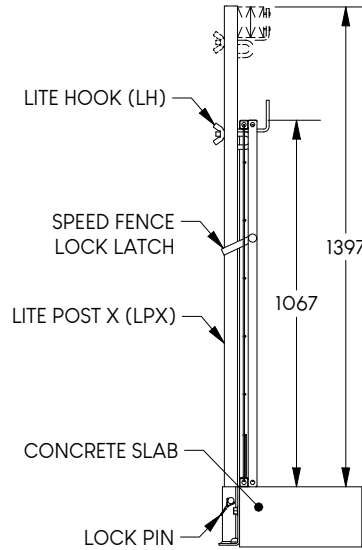

CONCRETE APPLICATION

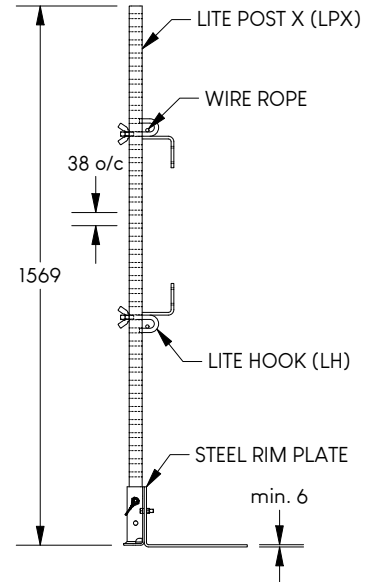

STEEL APPLICATION

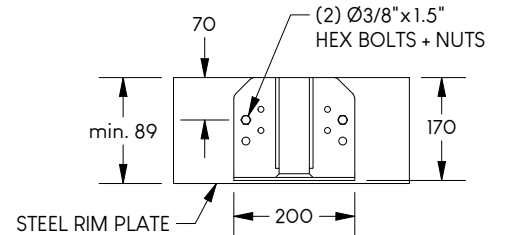
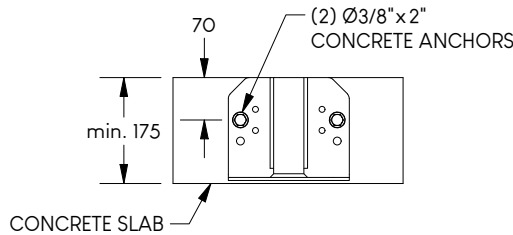
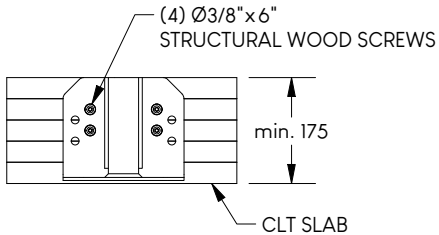

Compliant with load requirements of all Canadian Provincial Regulations for Construction Projects.

*Maximum post spacing applies when the guardrail system consists of only Speed Edge products.

Please inquire regarding compliance in other jurisdictions or for special case scenarios.

Refer to manual for complete installation instructions.

ALL MEASUREMENTS IN mm, U.N.O.

Weight	2.4 kg
*Max. Spacing	2743 mm