

# FENCE CONNECTIONS

# FC

## Speed Fence Connection Details

NOTE: EACH FENCE PANEL MUST BE SECURELY CONNECTED TO A SUPPORT POST AT EACH END

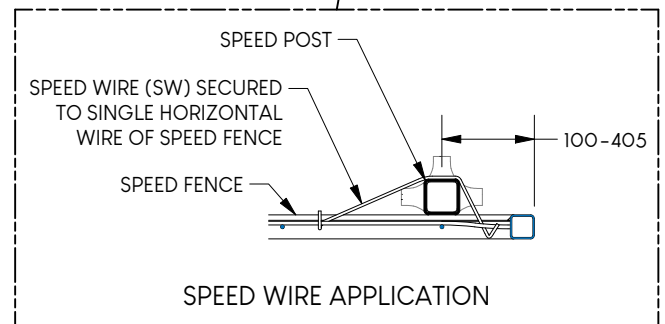
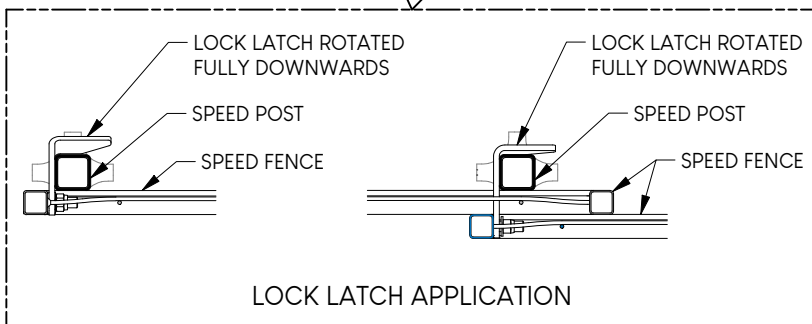
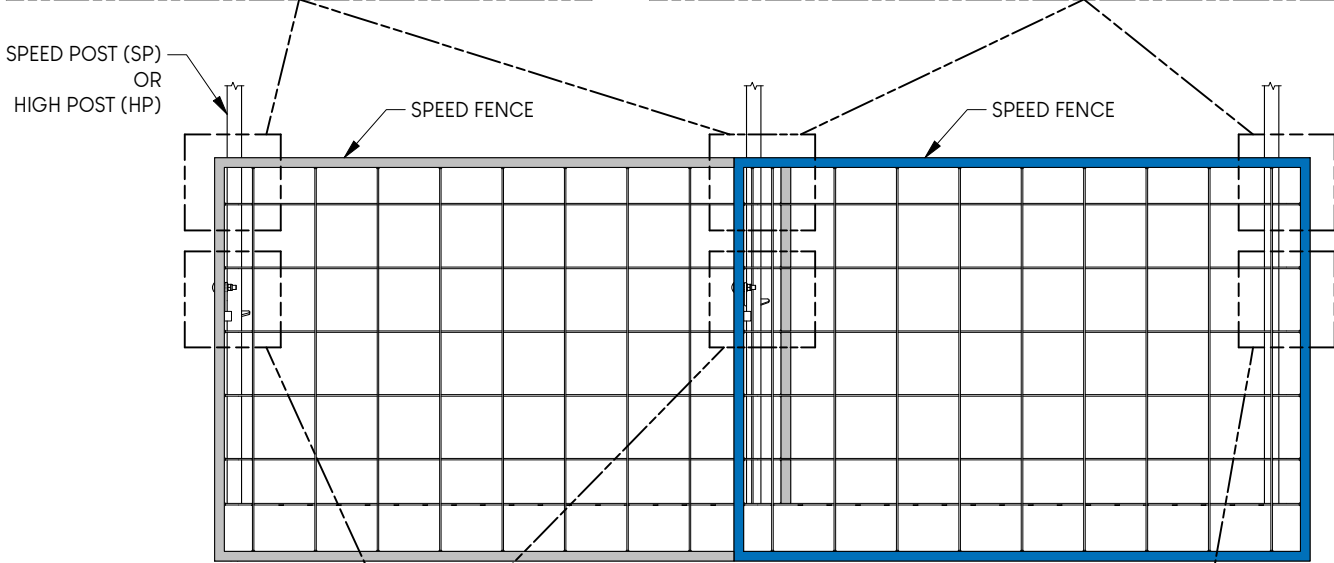
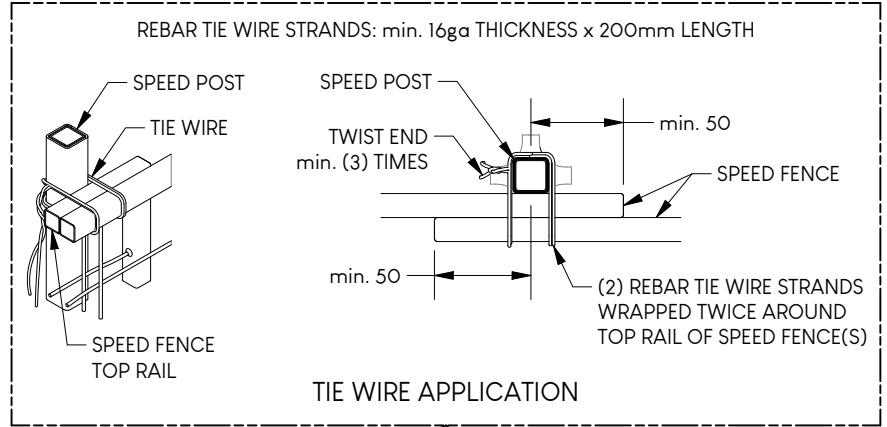
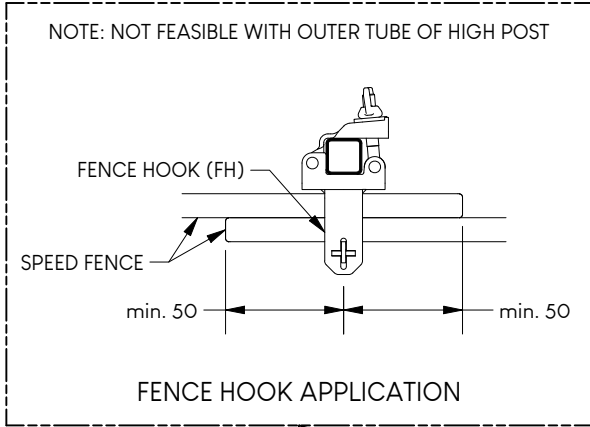

Compliant with load requirements of all Canadian Provincial Regulations for Construction Projects.

Please inquire regarding compliance in other jurisdictions or for special case scenarios.

Refer to manual for complete installation instructions.

ALL MEASUREMENTS IN mm, U.N.O.