

FENCE CONNECTIONS

FC

Speed Fence Connection Details

NOTE: EACH FENCE PANEL MUST BE SECURELY CONNECTED TO A SUPPORT POST AT EACH END

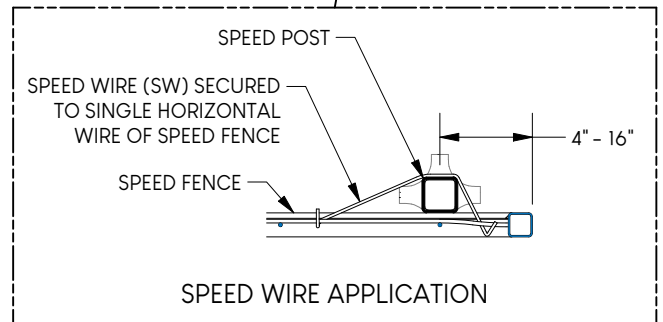
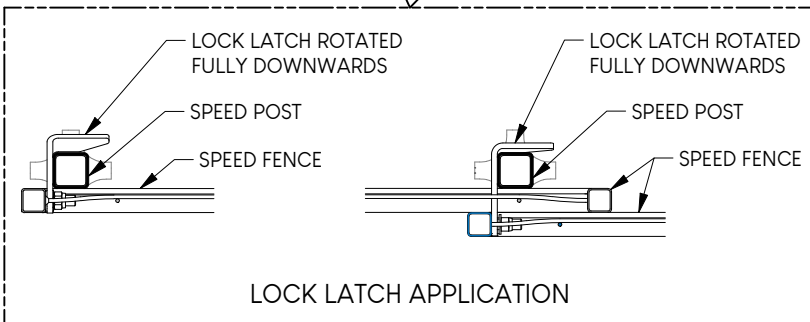
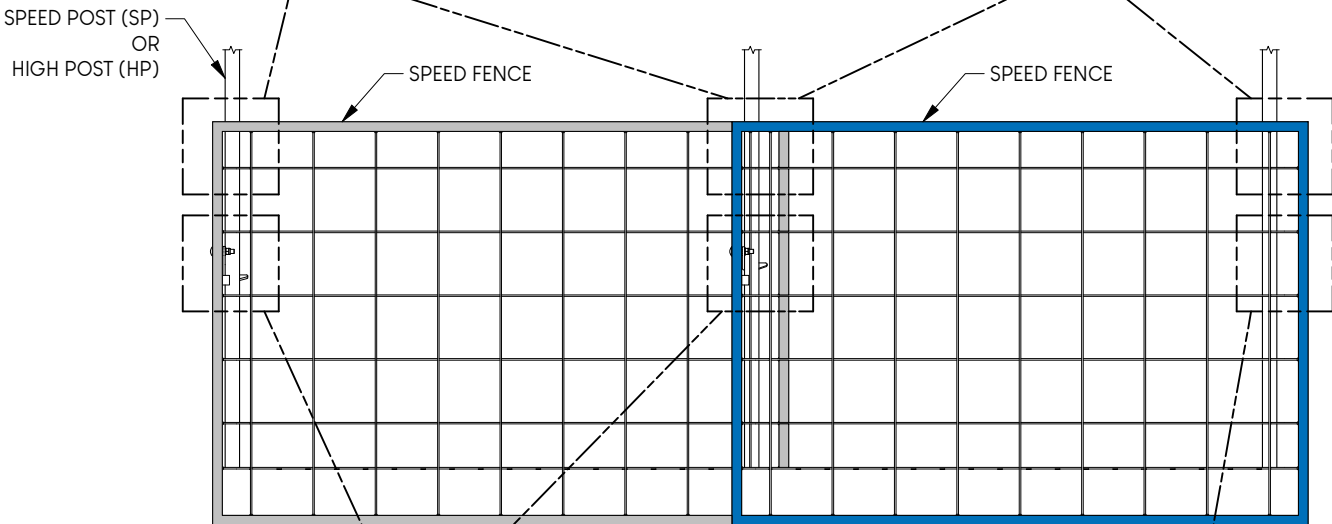
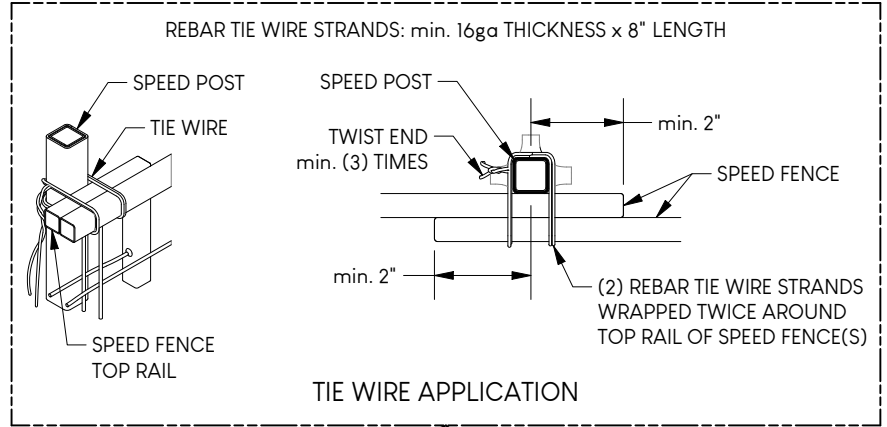
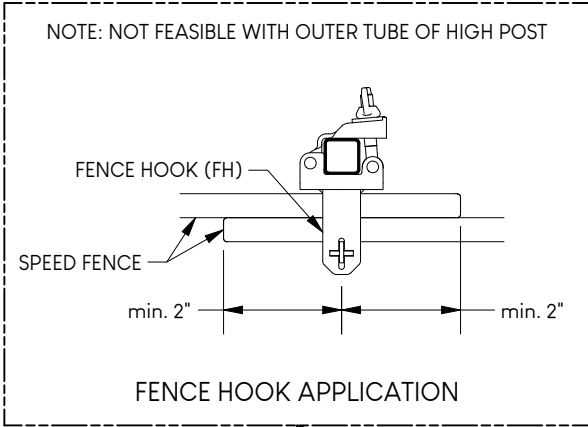

Compliant with all OSHA & Cal/OSHA load requirements for Construction Projects.

Please inquire regarding compliance in other jurisdictions or for special case scenarios.

Refer to manual for complete installation instructions.

ALL MEASUREMENTS IN inches, U.N.O.