

LUMBER BRACKET

LBR

Wooden 2x4 Mounting Bracket

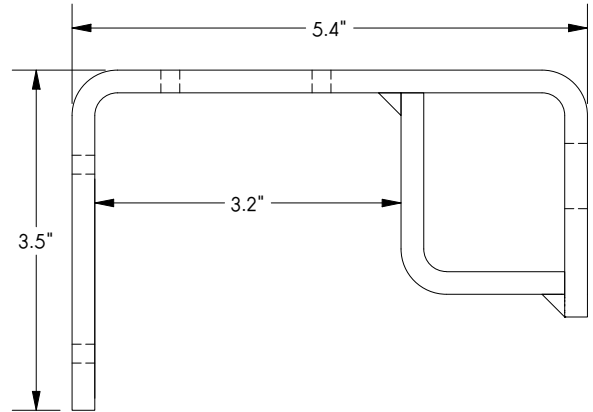
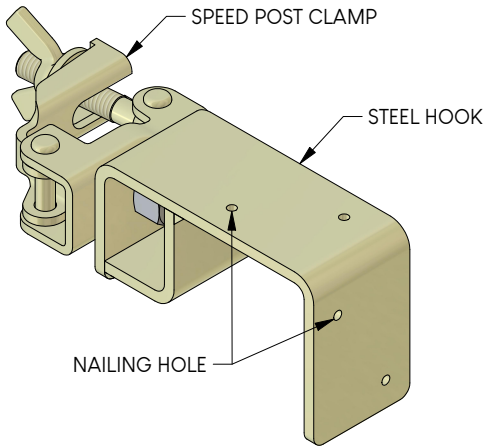

NOTE: FASTENING REQUIRED IN EITHER TOP/BOTTOM OR FRONT, NOT BOTH.

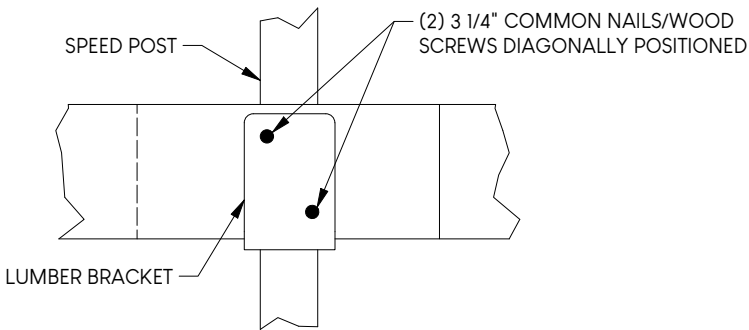

FASTENING REQUIREMENTS (FRONT)

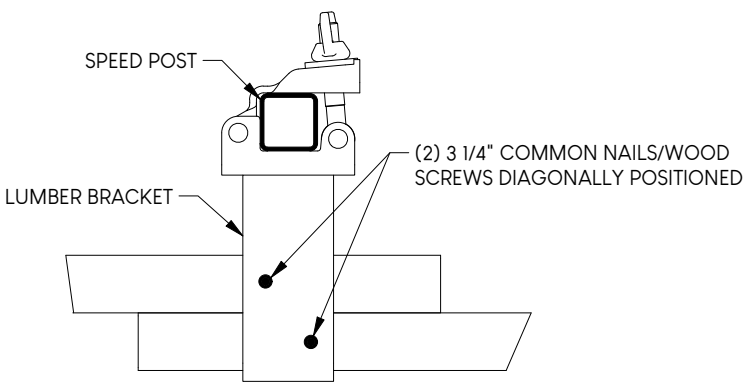

FASTENING REQUIREMENTS (TOP/BOTTOM)

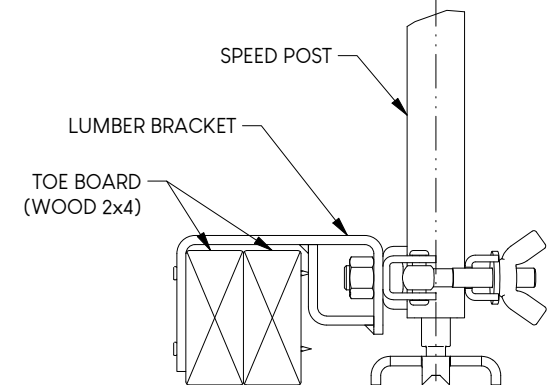
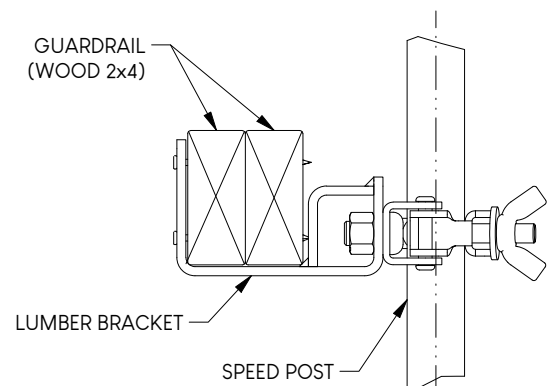

APPLICATION w/ SPEED POST

Compliant with all OSHA & Cal/OSHA load requirements for Construction Projects.
 Please inquire regarding compliance in other jurisdictions or for special case scenarios.
 Refer to manual for complete installation instructions.

ALL MEASUREMENTS IN inches, U.N.O.

Weight	4.0 lbs
--------	---------