

SPEED FAN INFILL NETTING

SFIN

Infill Net Connection Details

COUPLED INFILL NETTING

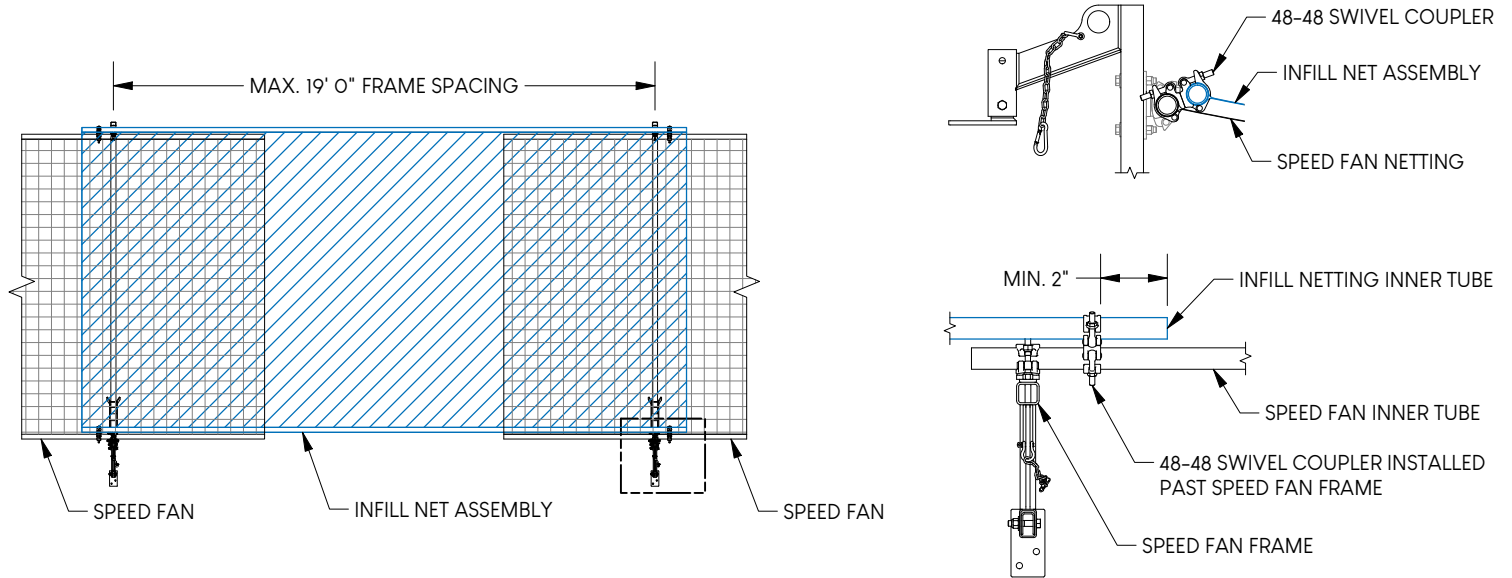

STITCHED INFILL NETTING

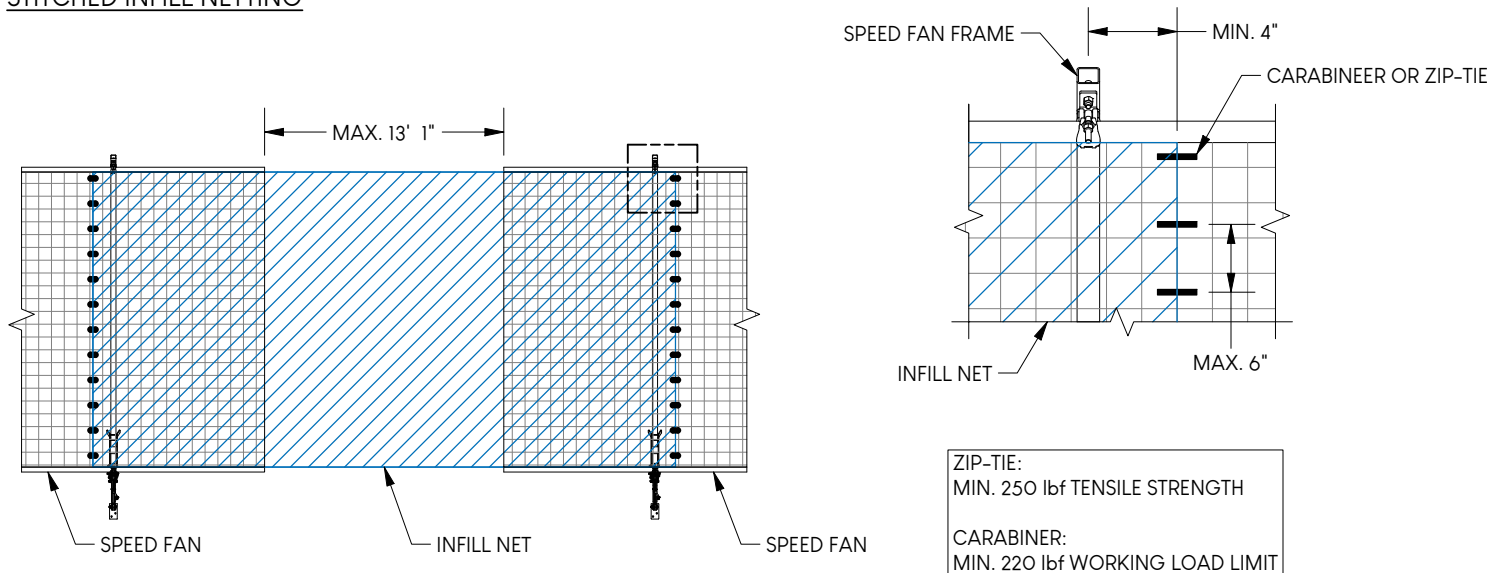

Compliant with all OSHA & Cal/OSHA load requirements for Construction Projects.

Please inquire regarding compliance in other jurisdictions or for special case scenarios.

System capacity is subject to layout & installation in accordance with the sealed site-specific typical drawing(s).

Refer to manual for complete installation instructions.

ALL MEASUREMENTS IN inches, U.N.O.