

STAIRWELL GUARDRAIL

SGL

Temporary Stairwell Edge Protection System

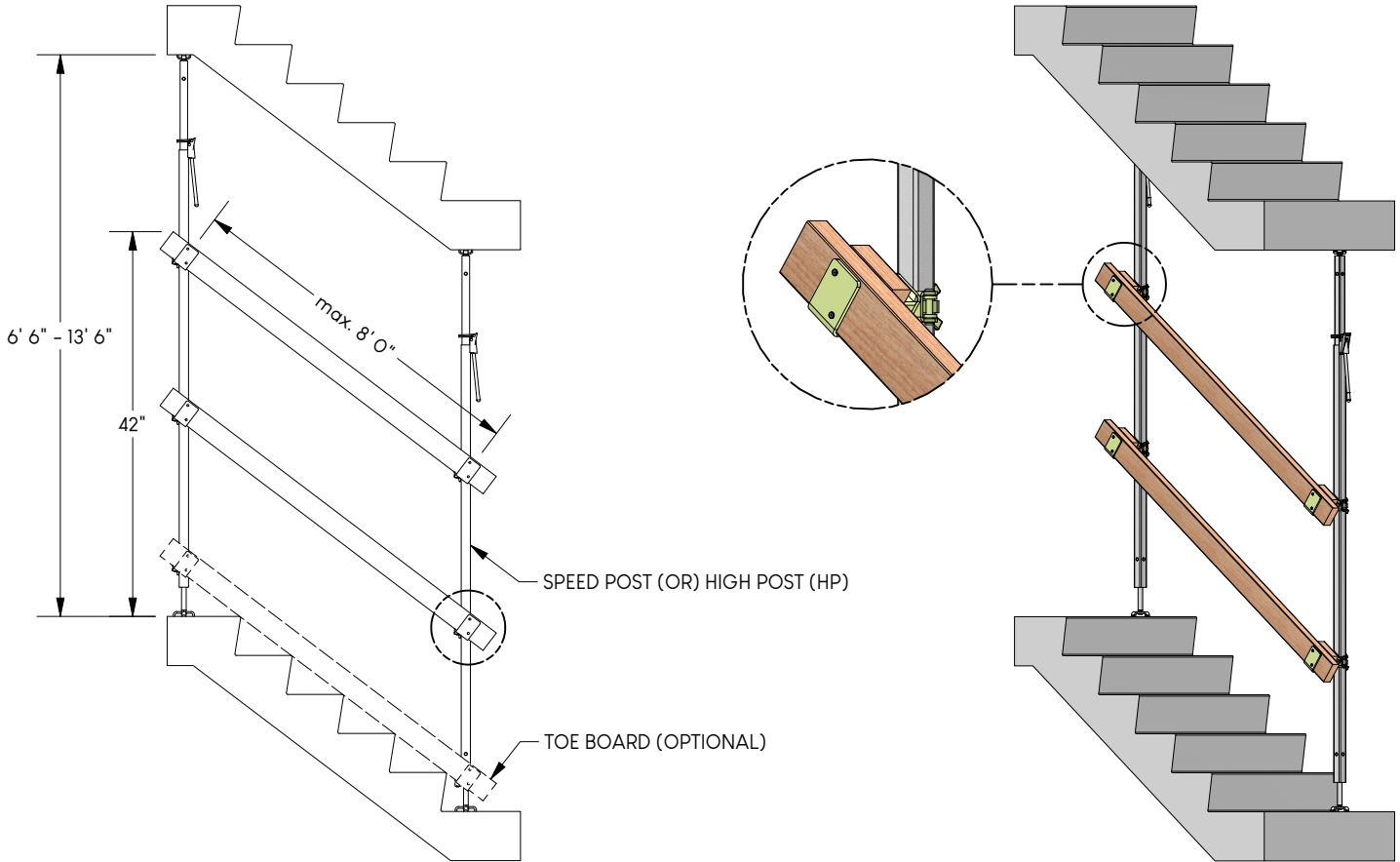

NOTE: GREATER GUARDRAIL SPANS CAN BE ACHIEVED WHEN USING 4x4 OR DOUBLE 2x4 DIMENSIONAL LUMBER RAILS (CONTACT SPEED EDGE FOR INFORMATION)

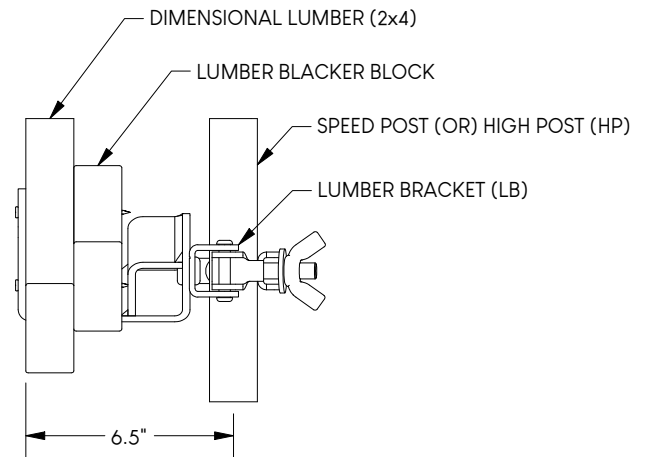
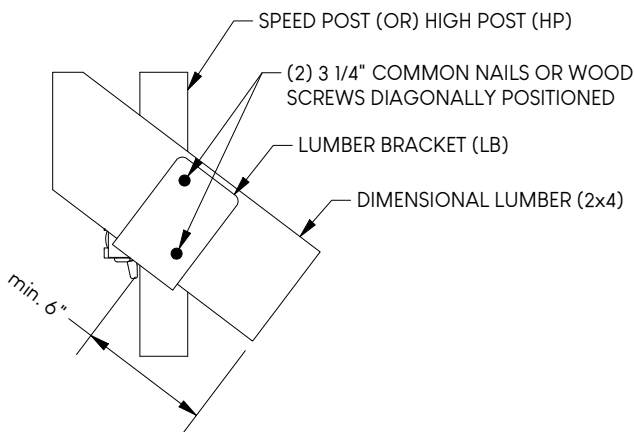

Compliant with all OSHA & Cal/OSHA load requirements for Construction Projects.
 Maximum span indicated only applies when the guardrail supports are Speed Edge products.
 Please inquire regarding compliance in other jurisdictions or for special case scenarios.
 Refer to manual for complete installation instructions.

ALL MEASUREMENTS IN inches, U.N.O.