

SPEED POST

SP

Adjustable Compression Post

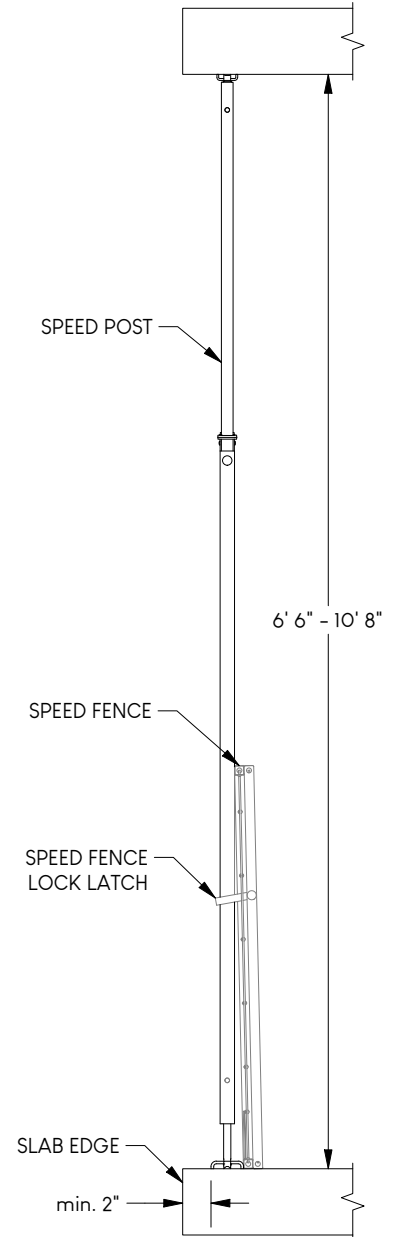
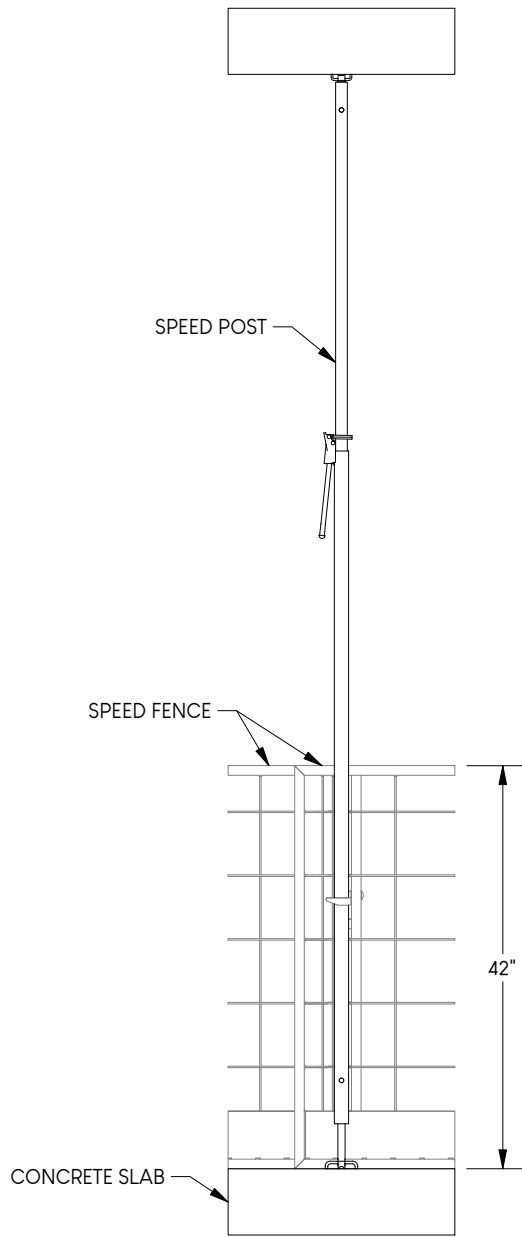
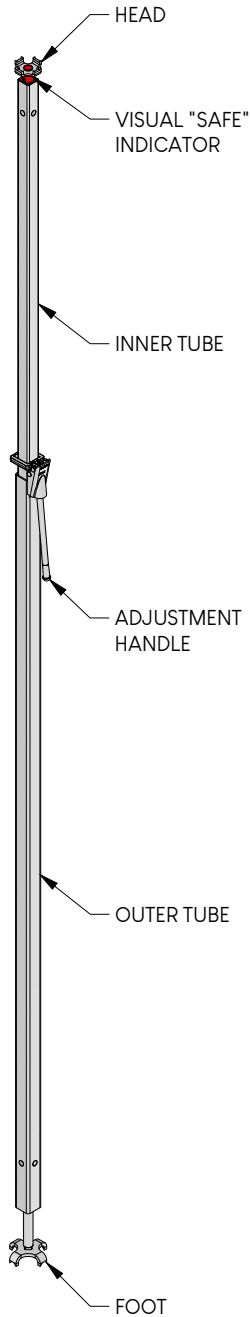

Compliant with all OSHA & Cal/OSHA load requirements for Construction Projects.
 *Maximum post spacing applies when the guardrail system consists of only Speed Edge products.
 Please inquire regarding compliance in other jurisdictions or for special case scenarios.
 Refer to manual for complete installation instructions.

ALL MEASUREMENTS IN inches, U.N.O.

Weight	24.5 lbs
*Max. Spacing	9' 0"
Storage Length	6' 6"