

SPEED SWIVEL CLAMP

SSC

Scaffold Tube Mounting Clamp

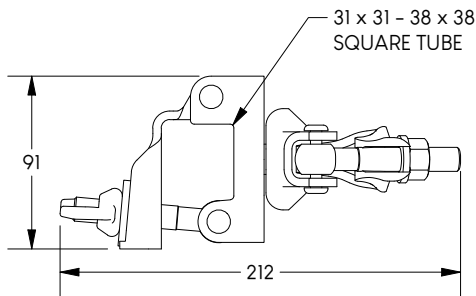
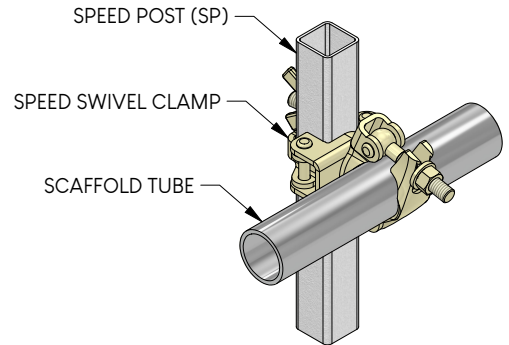
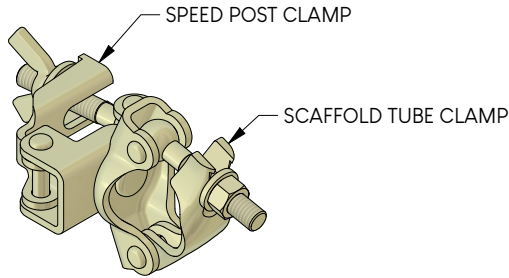

TOP VIEW

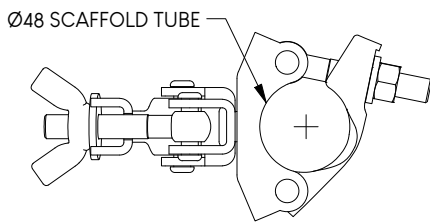

SIDE VIEW

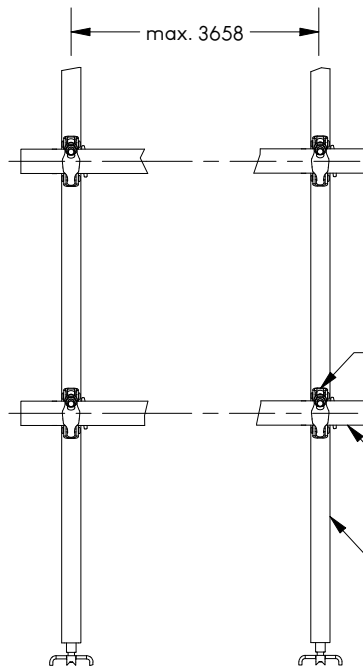

APPLICATION DETAILS
(FRONT ELEVATION)

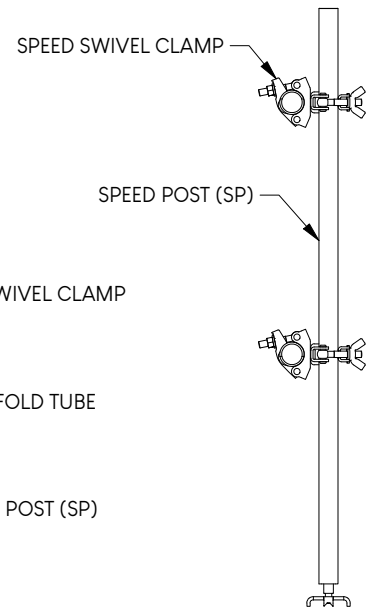

APPLICATION DETAILS
(SIDE ELEVATION)

Compliant with load requirements of all Canadian Provincial Regulations for Construction Projects.

Maximum span indicated only applies when the guardrail supports are Speed Edge products.

Please inquire regarding compliance in other jurisdictions or for special case scenarios.

Refer to manual for complete installation instructions.

ALL MEASUREMENTS IN mm, U.N.O.

Weight	1.1 kg
--------	--------